

Numerical Investigation of Flow and Dust Concentration Distributions in the Work Area of a Mountain Tunnel Currently under Construction

Chikao Kanaoka¹, Masami Furuuchi^{2*}, Thosihiko Myojo³, Jun-ichi Inaba², Kazuyo Ohmata²

¹ *Ishikawa National College of Technology, Kitacyujo, Tsubata, Kahoku-gun, Ishikawa, 929-0392, Japan*

² *Graduate School of Natural Science and Technology, Kanazawa University, Kakuma-machi, Kanazawa, 920-1192, Japan*

³ *Division of Human Engineering, National Institute of Industrial Health, Nagao 6-21-1, Tama-ku, Kawasaki, 214-8585, Japan*

Abstract

Flow patterns, dust concentration profile, and particle motion in a mountain tunnel under construction were calculated numerically for a full-scale tunnel to evaluate the effectiveness of the planned ventilation system. The influence of ventilation air flow rate, the configuration of air tubes, and an obstacle near the working face were investigated. The trajectories of different size particles were calculated at different wall conditions for deposition. A vortex flow was found to form between the air inlet and the working face for all ventilation types examined. The average dust concentration at a height of 1.5 m, corresponding to the average breathing height of a worker, did not consistently decrease with an increased air flow rate in an injection-suction type system. An optimal air flow rate for minimizing the dust concentration may exist. A vortex flow developed around an obstacle near the working face, leading to an increase in dust concentration between the obstacle and the working face. The concentration of dust near the working face was extremely high and was too spatially variable to be accurately described by the average dust concentration in the area between the working face and the air inlet. The fraction of particles removed through the air outlet was dependent on the ventilation pattern, and also decreased with increasing particle size due to immediate deposition of coarse particles on the tunnel floor.

Keywords: Numerical analysis; Ventilation; Dust concentration; Particle motion.

* Corresponding author: Tel: +81-76-234-4646; Fax: +81-76-234-4644

E-mail address: mfuru@t.kanazawa-u.ac.jp

INTRODUCTION

Mountain tunnels with cross sections larger than 50 m² are extensively used in railways and expressways in Japan. Cross-section driving or bench-cut driving procedures are typically employed in the construction of mountain tunnels with large cross sections. The air near the working face of a mountain tunnel that is currently under construction is highly contaminated with dust generated by excavation processes, such as drilling, blasting, dirt and debris removal by heavy duty machines, as well as spraying concrete with the NATM (New Austrian Tunnel Method) operation for reinforcing the tunnel wall. Similar problems have been reported for mining tunnels (Willeke *et al.*, 1998).

Since contaminated air may cause health problems and reduce working efficiency (Praml *et al.*, 1992, 1995; Vogel *et al.*, 2001), consideration is given to controlling dust generation, using effective air ventilation systems, and personal filtration devices in order to minimize exposure problems caused by contaminated air. A concentration of 5 mg/m³ of total dust has been applied by Ministry of Health and Welfare, Japan (the present Ministry of Health, Labour and Welfare, Japan) as a limiting value for concentration control.

Air ventilation systems, which supply fresh air from outside the tunnel to the working face, have been widely adopted for reducing the dust concentration in the tunnel (Yoshikawa *et al.*, 1967; Japan Association of Tunnel Technology, 1985; Japan Association of Mechanization of Construction, 1994; Praml *et al.*, 1995; Vogel *et al.*, 2001). Typical air ventilation systems in current use are the injection type, in which fresh air is supplied through an air tube, while contaminated air flows out through the tunnel exit. The injection type is usually used in tunnels shorter than 500-1000 m, or at earlier stages in the construction of tunnels longer than 500-1000 m. This type has the advantage of being low cost, but the disadvantage of low dust removal efficiency. The tunnel itself becomes the duct for dirty air, spreading pollution throughout the underground network.

An alternative system, the injection-suction type, employs air tubes for both the air supply and the exhaust. This type ventilates more effectively than the injection system, but its high initial cost is a problem. Its ventilation efficiency is sensitive, as well, and is dependent on air-tube configuration and operating conditions. Hence, the configuration chosen for use must be considered very carefully.

In the space near the tunnel working face, the air flow and dust concentration profiles are very complicated due to multiple factors, including dust generation rate, the ventilation pattern and air flow rate, air-tube configuration, and the operation of heavy-duty machines (Harada *et al.*, 1994; Praml *et al.*, 1995). These effects have not been systematically and quantitatively studied with respect to the relationship between air flow (which is essentially affected by the air-tube configuration) and the distribution of dust in the work space (Ohashi, *et al.*, 1994). So far, system operation methods and choices have been based on experience,

and not on theoretical grounds.

In the present study, the influence on dust concentration of ventilation flow pattern, air flow rate, air-tube configuration, and an obstacle near the working face are numerically evaluated. The influence of particle size on particle motion and the fraction of particles removed from the tunnel are also discussed.

COMPUTATIONAL MODEL

Model Geometry

A mountain tunnel was modeled, as shown in Fig. 1, using the same dimensions as an actual tunnel for a two-lane highway without any sub-tunnel connections. The work space between the air inlet and the working face of the model tunnel were ventilated by fresh air supplied through air tubes running along the tunnel ceiling.

Two different types of ventilation systems, shown in Fig. 2, were tested: 1) injection, and 2) injection-suction types. Three different configurations of air tubes (labeled types I, II and III, diameter 1.7 m), shown in Fig. 2, were also examined for the latter system in order to investigate the influence of different flow patterns. The inlet and outlet of the air tubes were located at 50 and 100 m, respectively, from the working face. The axial scale of the calculated area was 100 m for the injection type and 220 m for the injection-suction type so as to make the boundary conditions at the tunnel exit as similar as possible to those in an actual tunnel.

The influence of an obstacle near the working face was examined by using the model shown in Fig. 3, and compared to a case with no obstacle.

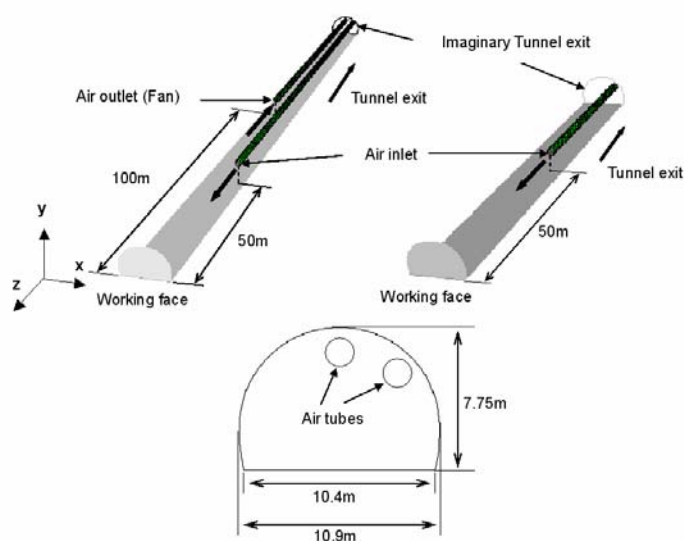

Fig. 1. Calculation model.

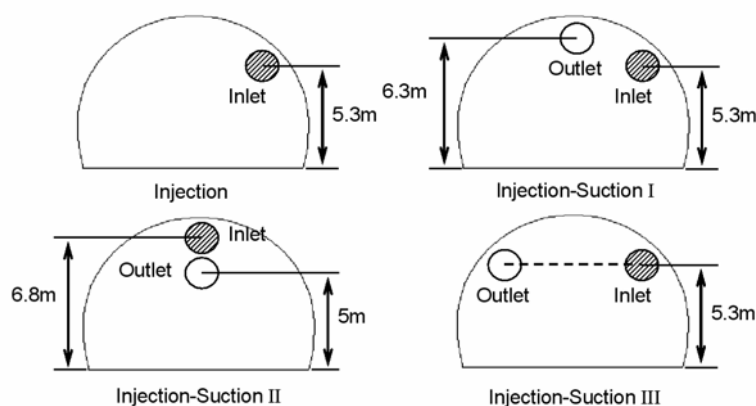

Fig. 2. Types of ventilation systems and air-tube configurations.

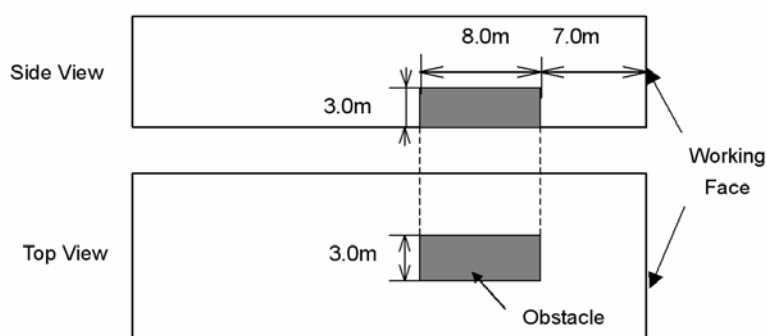

Fig. 3. Model of an obstacle.

Calculation Methods

Steady state fluid flow and dust concentration distribution were calculated using the standard $k-\varepsilon$ turbulence model. All calculations were performed using *FLUENT*, ver. 5.2 (FLUENT, Inc.), based on the control volume scheme (Patanker, 1980). The calculation conditions are summarized in Table 1. The coefficients in $k-\varepsilon$ equations from Landauer *et al.* (1972), which had been idealized for fully developed turbulent flow, turbulent intensity, and length scale typical of a tube flow, were used for the calculations (Anderson, 1995). This model has been used in the numerical simulation of flow through the traffic tunnel using FLUENT (Ballesteros-Tajadura *et al.*, 2006; Bari *et al.*, 2005), and also using other CFD procedures (Jia *et al.*, 1996; Chung *et al.*, 2004). The properties of air under the ambient condition (100 kPa, 20°C) were used and the air temperature was assumed to be uniform throughout the tunnel. The number of elements for the numerical procedure ranged from 1.7×10^5 to 2.1×10^5 with the uniform grid size, where the grid size was determined, taking into account the convergence and CPU time. The calculation was terminated when the relative difference between iterations became less than 0.1% for all variables. The total CPU time

ranged from ca. 80 to 120 min on a Windows PC (Celeron® 2.93 GHz, 504 MB RAM) depending on the number of elements.

Table 1. Calculating conditions.

(a) Tunnel geometry

Cross sectional area:	70 m ²
Distance between air inlet and working face:	50 m
Distance between air outlet and working face:	100 m
Air tube diameter:	1.7 m

(b) Ambient air properties

Density:	1.2k g/m ³
Viscosity:	1.8×10 ⁻⁵ Pa·s
Temperature:	293 K
Pressure:	1.013×10 ⁵ Pa

(c) Boundary conditions

Wall	Velocity	0 m/s
Tunnel exit	Gauge pressure	0 Pa
(Pressure boundary)	Turbulence intensity	5%
	Turbulent length scale	0.49 m
Air inlet	Velocity in z-direction	3.67, 7.34, 12.5, 22.0, 36.7 m/s
	(along the tunnel axis)	
(Velocity boundary)	Turbulence intensity	5%
	Turbulent length scale	0.119 m
Air outlet	Gauge Pressure	120, 210, 460, 1100, 2600 Pa
(Pressure boundary)		

The flow rates of the supplied air listed in Table 2 were used as the input, where Q^* denotes the flow rate normalized by an actual injection flow rate of 1700 m³/min. The difference between injection and suction flow rates was fixed at 500 m³/min so as to avoid excess flow toward the tunnel exit. The pressure at the air outlet was adjusted so as to give the required suction flow rate.

Table 2. Flow rates of ventilation air used in the calculations.

Normalized flow rate	Injected air (m ³ /min)	Sucked air (m ³ /min)
Q*=0.29	500	1000
Q*=0.59	1000	1500
Q*=1	1700	2200
Q*=1.76	3000	3500
Q*=2.94	5000	5500

Dust Concentration and Particle Motion

Dust Concentration Distributions

Dust concentration distributions were calculated by assuming the dust-laden air to be a fluid having the same density as air. Since this calculation is applicable only when the particle size is sufficiently small enough to neglect the influence of gravity and inertia, the results were compared with those for a particle trajectory calculation.

Diffusion of dust was calculated from the equation for convective diffusion (Eq. (1)) (Bird *et al.*, 1960).

$$\frac{\partial}{\partial t}(\rho m) + \frac{\partial}{\partial x_i}(\rho u_i m) = -\frac{\partial J_i}{\partial x_i} \quad (1)$$

$$J_i = -\left(\rho D + \frac{\mu_i}{Sc_i}\right) \frac{\partial m}{\partial x_i} \quad (2)$$

where D is the molecular diffusivity, I is 1,2,3, x_I is the horizontal direction, x_2 is the vertical direction, x_3 is the axial direction of the tunnel, m is the mass fraction of dust, Sc is the turbulent Schmidt number (0.7), which is the default value for all turbulent flows used in FLUENT, u_i is the air flow velocity component, μ_i is the turbulent viscosity and ρ is the density of air. With reference to data for the dust-generation rate (1.2-4 g/min) in actual tunnels (Japan Construction Safety and Health Association, 1985), particles were generated uniformly at a rate of 3 g/min from the working face.

Particle Motions

Various particle sizes have been reported to be generated during tunnel construction processes (Willeke *et al.*, 1993; Japan Construction Safety and Health Association, 1997; Praml *et al.*, 1987, 1992; Weidhofer and Winker, 2001; Vogel *et al.*, 2001); e.g., nano to several micron-sized soot particulates from diesel vehicles, and coarse particles greater than 100 μm generated during *NATM* operation. The continuum assumption of dust-laden air is not valid for such a wide range of particles, and so the motion of an individual particle must be analyzed.

The trajectory of a spherical particle was calculated by numerically integrating the following equation of particle motion (Hinds, 1999):

$$m \frac{du_{pi}}{dt} = F_{Di} + g_i (\rho_p - \rho) \quad (3)$$

$$F_{Di} = C_D \frac{\pi D_p^2}{4} \cdot \frac{\rho |u_{pi} - u_i| (u_{pi} - u_i)}{2} \cdot \frac{1}{C_c} \quad (4)$$

where F_{Di} is the drag force acting on the particle, $i=1,2,3$ where u_{pi} the particle velocity component, ρ_p the density of particle, D_p the particle diameter and C_c the Cunningham correction factor. Re is the relative Reynolds number, which is defined as:

$$Re = \frac{\rho D_p |u_{pi} - u_i|}{\mu} \quad (5)$$

where μ the fluid viscosity. The drag coefficient C_D is assumed to be the following function of Re :

$$C_D = a_1 + a_2/Re + a_3/Re^2 \quad (6)$$

where the $\{a_i\}$ are constants given as a function of Re (Morsi and Alexander, 1972). Eq. (3) allows one to calculate the particle trajectory along the average velocity field of air flow without taking into account the influence of diffusion due to the turbulent mixing, in which the particle size effect on the molecular diffusion of particles can be reasonably assumed as negligible.

Fig. 4 depicts particle-generating positions. Particle trajectories were calculated for a given period after their generation. The fractions of generated particles removed from the air outlet or the tunnel exit were also evaluated: 425 particles with the initial velocity perpendicular to the working face were instantaneously generated at the centre of each element. Particle properties are listed in Table 3. The initial velocity u_{p0} of the generated particles was assumed to be the same as the velocity of the particle-laden gas existing at the working face. Since the stopping distance of a particle ($= \rho_p D_p^2 u_{p0} / (18\mu)$) (Hinds, 1999) of 0.1-100 μm corresponds to a mesh size of 1/1000-1/10 even for $u_{p0} = 10$ m/s, the influence of initial velocity can be neglected.

Exuding underground water usually wets the tunnel wall, and the size of the wet area can change with the part covered by concrete. This surface condition influences the deposition and re-suspension of particles. Therefore, two different wall boundary conditions were tested in order to evaluate the influence of the tunnel wall's surface conditions: 1) particles deposited on every wall, 2) particles deposited only on the tunnel floor while assuming a perfect elastic particle bouncing on the remaining wall, that is, the side wall and the work face.

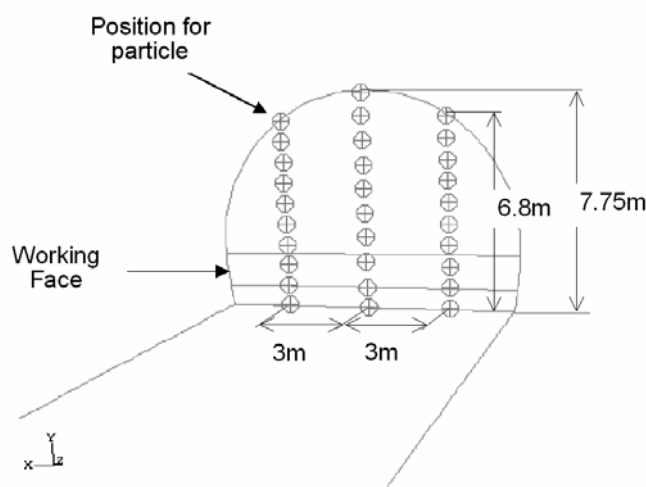

Fig. 4. Positions of particle generation.

Table 3. Properties of particles.

Shape	spherical
Diameter	0.1, 1, 2, 5, 7, 10, 100 μm
Density	2500 kg/m^3
Initial velocity	0.016 m/s

RESULTS AND DISCUSSION

Influence of Ventilation Pattern and Air-Tube Configuration

In Figs. 5(a)-(d), the streaked lines from the air inlet for $Q^*=1$ are shown for each ventilation type. Fresh air flows toward the working face, then when near turns around and flows out of the work space through either the air outlet or the tunnel itself. Regardless of the ventilation type, eddies form between the air inlet and the working face, and the eddy size and intensity change with the ventilation type used.

Fig. 6 depicts dust concentration distributions in the vertical cross-section along the tunnel axis for each ventilation type. A higher dust concentration was found for the injection type, especially around the tunnel ceiling. When the air tubes are parallel along the tunnel ceiling (e.g., the injection-suction type III), the concentration decreases considerably within an area more than 10 m from the working face.

The distributions of dust concentration at a height of 1.5 m from the tunnel floor, which corresponds to the height of a worker's face, are plotted in Fig. 7 for the injection-suction type I system. Each curve depicts the distribution at a different x -coordinate corresponding to each element for numerical calculation. The dust concentration reaches a maximum at the working

face, where particles are generated, and rapidly decreases with the distance from the working face. It should be noted that a constant concentration region exists between the air inlet and outlet. The dust concentration decreases at the air outlet. In the area between the air inlet and the working face, the concentration is higher on the air inlet side. As can be seen from Fig. 7, the average concentration in the area between the working face does not adequately account for the extremely high-concentration region near the working face, although this kind of concentration index has been used in dust concentration management (Japan Construction Safety and Health Association, 1986).

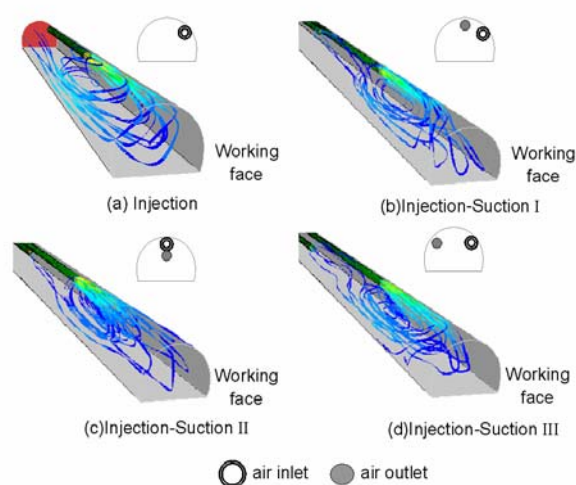

Fig. 5. Streamed lines of ventilation air inside the tunnel.

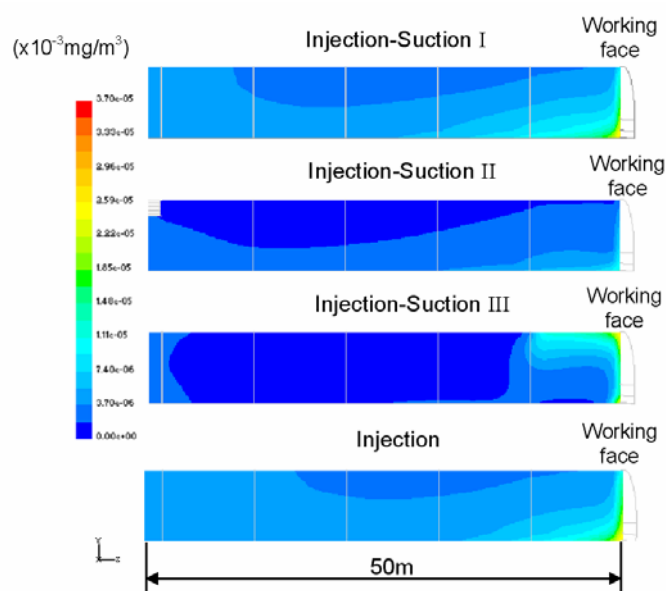

Fig. 6. Dust concentration distributions in a vertical cross-section along the tunnel axis calculated for each ventilation type.

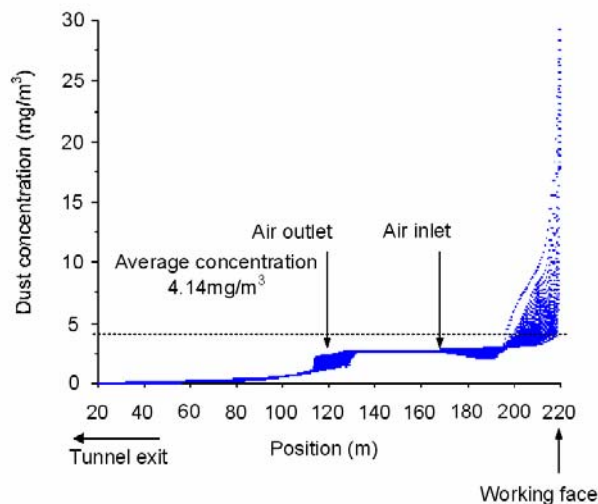

Fig. 7. Dust concentration distributions in a horizontal cross-section at a height of 1.5 m from the floor for the injection-suction type I system compared with the geometric mean value of measured values from the guidelines.

Influence of Ventilation Flow Rate

Average concentrations in the horizontal cross-section at a height of 1.5 m from the floor are plotted against air flow rate as shown in Fig. 8. The average dust concentration in the injection type system is not affected by the air flow rate. The injection-suction types are able to reduce the concentration, though it does not decrease monotonically with flow rate; rather, an optimal air flow rate may exist for minimizing the dust concentration. This may be because an increased air flow rate dilutes the dust, but enhances the mixing of the flow around the working face.

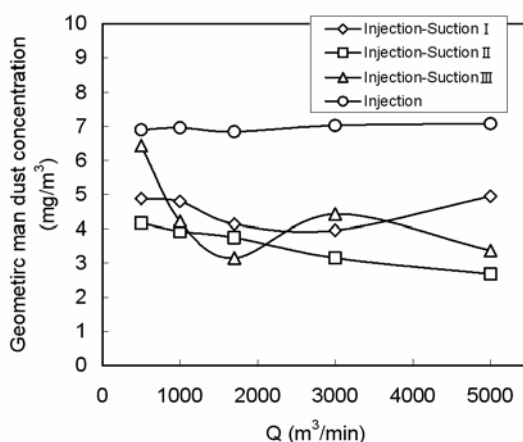

Fig. 8. Average dust concentration in a cross-section at a height of 1.5 m from floor plotted against air flow rate.

Influence of an Obstacle near Working Face

Dust concentration distributions, when an obstacle is located near the working face, are compared with those without an obstacle present (Fig. 9), in which vertical cross-sections along the tunnel axis (side view) and horizontal cross-sections at 1.5 m heights are shown for the injection-suction type III system. Regardless of the air-tube configuration, eddies are formed behind the obstacle, where dust concentration increases. This effect may increase considerably with the size and number of obstacles. Therefore, the configuration of heavy-duty vehicles near the working face should be carefully considered.

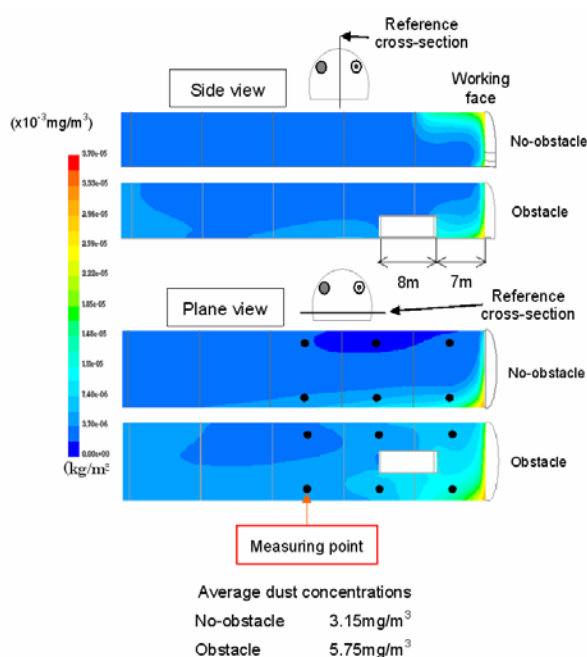

Fig. 9. Influence of an obstacle near the working face on dust concentration distribution.

Particle Motions

Particle trajectories are shown in Fig. 10 for different particle sizes, where particles are assumed to deposit on every wall without re-suspension. Since the influence of gravity and inertia are significant for large particles of 100 μm , they deposit on the floor under the working face. Small particles, with sizes below 10 μm are largely carried by the air and are removed through the air outlet or the tunnel exit, although some fractions return to the working face and are suspended in the work area.

Fig. 11 demonstrates the influence of the air flow rate on particle trajectory. When $Q^* = 0.29$, i.e., at a moderate flow rate, particles are entrained in the vortex flow and are retained in the work space. When $Q^* = 0.59$, the particles do not return to the working face. This will reduce the dust concentration as described previously by the continuum calculations. The continuum approximation may accurately predict particle concentration less than 10 μm in diameter.

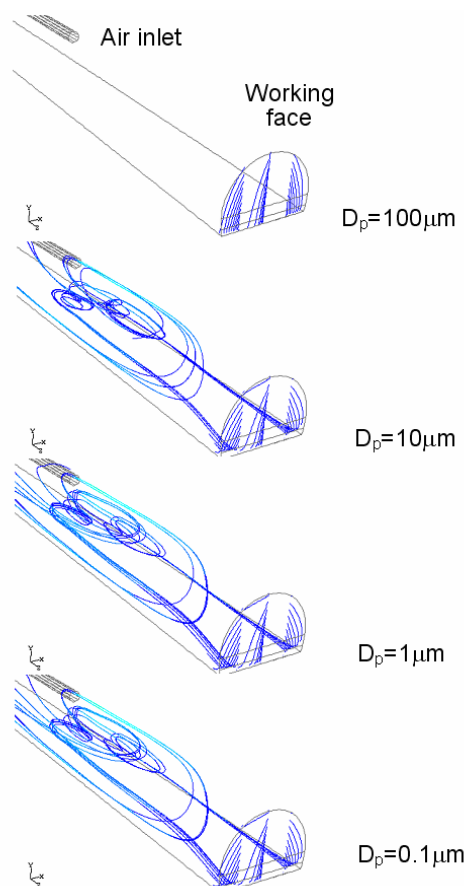

Fig. 10. Trajectories of particles as a function of size (Injection-Suction I, $Q^*=1$).

Figs. 12 (a) and (b) show the relation between particle diameter and the fraction of particles removed from the air outlet or tunnel exit, where the particles were assumed to deposit everywhere and only on the floor, respectively. In the former case, most particles cannot flow out the tunnel, but are deposited on the wall; the injection type system removes 20% of the generated particles, while 10% of the particles are removed by the injection-suction type I system. When the particles are deposited only on the floor, the injection-suction type III system is able to remove 80% of the particles. A comparison of the results in Figs. 12 (a) and (b) shows that 80% of the particles are deposited on the sidewall in the injection-suction type III system, while most of the particles are deposited on the floor in the injection-suction type II system. Regardless of the wall conditions, the ventilation pattern, or the air-tube configuration, particles larger than $10\ \mu\text{m}$ cannot be removed from the air outlet or tunnel exit but deposited immediately on the tunnel floor, showing that only fine and respirable particles, which can penetrate deep into the lung, are retained in the work space.

As can be seen from the above results, dust concentration is strongly affected by flow pattern, particle size, and wall condition. The re-suspension of deposited particles is also an important factor, although it is not discussed here. In order to determine the optimal ventilation conditions, these factors should all be taken into account.

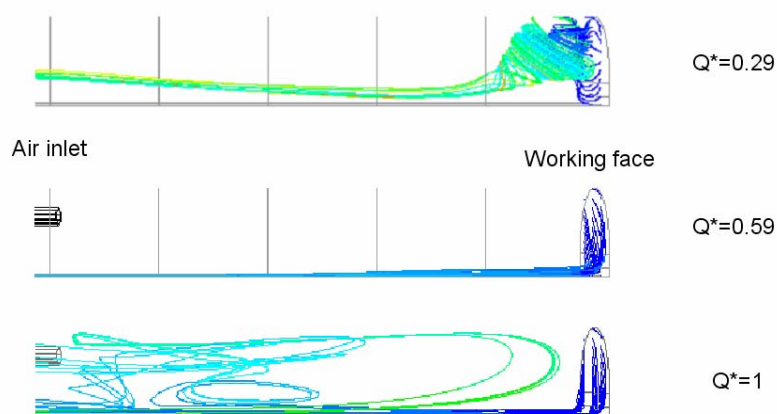

Fig. 11. Influence of air flow rate on particle trajectory ($D_p = 2.5 \mu\text{m}$, Injection-Suction I).

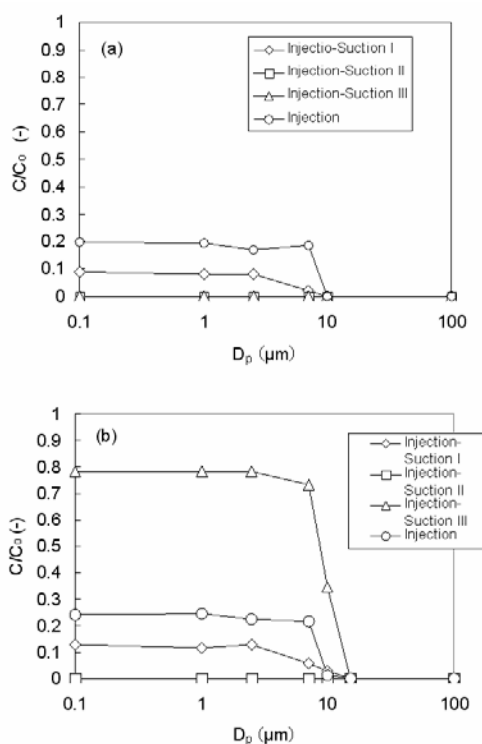

Fig. 12. Relation between particle diameter and the fraction of particles removed from the air outlet or tunnel exit C/C_0 , where the particles are assumed to be deposited (a) everywhere on the tunnel wall, and (b) only on the tunnel floor.

CONCLUSIONS

- 1) The injection-suction type ventilation system was able to reduce dust concentration more effectively than the injection type system.

- 2) A vortex flow developed around an obstacle near the working face, leading to an increase in dust concentration at that location.
- 3) An increase in air flow rate did not always decrease the dust concentration, and an optimal flow rate for minimizing the dust concentration may exist.
- 4) The dust concentration near the working face was extremely high, but it cannot be accurately described by the average dust concentration in the area between the working face and the air inlet.
- 5) The fractions of dust removed from the air outlet or tunnel exit decreased with increasing particle size, and they were influenced by the ventilation pattern and wall conditions for particle deposition. Respirable particles smaller than 10 μm are likely to remain suspended in the work area.

ACKNOWLEDGEMENT

The authors gratefully acknowledge Dr. R. C. Brown, Health & Safety Laboratory, Broad Lane, Sheffield, UK for his valuable comments.

REFERENCES

- Anderson, J.D.JR. (1995). *Computational Fluid Dynamics*, McGraw-Hill, New York.
- Balleseteros-Tajadura, R., Satolaris-Morros, C., and Blanco-Marigorta, E. (2006). Influence of the Slope in the Ventilation Semi-transversal System of an Urban Tunnel. *Tunneling and Underground Space Technol.* 21:21-28.
- Bari, S., and Naser, J. (2005). Simulation of Smoke from a Burning Vehicle and Pollution Levels Caused by Traffic Jam in a Road Tunnel. *Tunneling and Underground Space Technol.* 20:281-290.
- Bird, R.B., Stewart, W.E., and Lightfoot, E.N. (1960). *Transport Phenomena*, John Wiley & Sons, New York.
- Chung, C.Y., Chung, P.L., and Chen, K.S. (2004). Three-dimensional Air Quality Modeling in a Road Tunnel. Proc. J. Air Waste Manag. Assoc. Annual Meet. and Exhibit. pp. 5297-5308.
- Harada, M, Hizuka Y. and Tsuruta, M. (1994). Studies on the Application of "Air Way Ventilation Method" to the Ventilation for the Tunnel-driving (in Japanese). *Kashima Technical Research Center Annual Reports.* 20:249-264.
- Hinds, W.C. (1999). *Aerosol Technology*, 2nd ed., Wiley-Interscience, New York.
- Japan Association of Mechanization of Construction (1994). Ventilation System for Tunnel Construction using Fussy Theory (in Japanese), Report on Technology for Mechanization of Construction and Engineering Inspection Proof.
- Japan Association of Tunnel Technology (1985). Reports on the Working Environment in Tunnel during the NATM Operation (in Japanese).

- Japan Construction Safety and Health Association (1986). *The Guideline for the Dust Measurement in Underground Construction*.
- Japan Construction Safety and Health Association (1998). Report on Survey on Silicosis Countermeasures for Newly Developed Tunnel Driving Technologies Including NATM, Volume for Materials: Results on Examination and Summarization of Working Environment in Tunnel (in Japanese).
- Jia, M., Goto, M., and Ohbuchi, M. (1996). Numerical Simulation of the Natural Ventilation of a Road Tunnel (1996). *American Soc. Mech. Engineers, Fluid Eng. Div.* 239:483-489.
- Landauer, E., and Spalding, D.B. (1972). *Lectures in Mathematical Models of Turbulence*, Academic Press, London.
- Morsi, S.A., and Alexander, A.J. (1972). An Investigation of Particle Trajectories in Two-phase Flow Systems. *J. Fluid Mech.* 55:193-208.
- Ohashi, S., Harada, M., and Hizuka, Y. (1994). On the Ventilation Facilities During the Tunnel Driving (in Japanese). *Kashima Technical Research Center Annual Reports.* 18: 225-235.
- Patankar, S.V. (1980). *Numerical Heat Transfer and Fluid Flow*, Hemisphere Publishing Co., New York.
- Praml, G., and Kessel, R. (1987). Continuous Full Shift Personal Dust Exposure Monitoring. *J. Aerosol Sci.* 18:911-914.
- Praml, G., Hartmann, A. L., Droz, P.O., Kessel, R., and Fruhmann, G. (1995). Spritzbeton in Nass-spritzverfahren - das Ende der Staubprobleme im Tunnelbau?. *Verh Dtsch Ges Arbeitsmed Umweltmed.* 35:289-293.
- Praml, G., Hartmann, A.L., Droz, P.O., Kessel, R., and Fruhmann, G. (1995). Spritzbeton im Tunnelbau - Die langfristige Entwicklung der Staubexposition. *Zentralblatt fuer Arbeitsmedizin. Arbeitsschutz und Ergonomie mit Beiträgen zur Umweltmedizin.* 45:86-93.
- Praml, G., Kessel, R., and Hartmann, A. L. (1992). Staubbelastung Durch Untertägige Spritzbetonbaumweise: Kontinuierliche und Personenbezogene Erfassung, Proc. International Colloquium on Industrial Medicine in the Building Trades, Baden-Baden, Germany. pp. 294-298.
- Vogel, M., and Rast, H. P. (2001). AlpTransit-safety in Construction as a Challenge: Health and Safety Aspects in Very Deep Tunnel Construction. *Tunnelling and Underground Space Technol.* 15:481-484.
- Weidhofer, J., and Winker, N. (2001). VERT - Findings of the International Project to Diminish the Emission Values of Existing Diesel Engines in the Tunnel Construction. *Atemwegs-und Lungenkrankheiten.* 27:155-161.
- Willeke, K., and Baron, P. A. (1998). *Aerosol Measurement*, Wiley-Interscience, New York.
- Yoshikawa, K. (1967). Ventilation of Tunnel under Construction of Japan National Railways

(in Japanese). *Mechanization of Construction*. 204:16-22.

Received for review, March 21, 2006

Accepted, May 25, 2006